

# SM-9000

**Product** Massage Chair

**Model** SM 9000

Developed by AJX Distribution LLC

7001 Village Dr #250

Buena Park, CA 90621

**Tel** 1-855-646-9500

**Email** INFO@KAHUNACHAIR.COM

# KAHUNA MASSAGE CHAIR®

# SM-9000

Massage Chair Manual

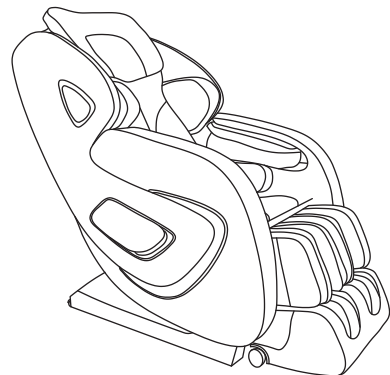

INSTRUCTION MANUAL  
MODEL:SM 9000

Please read this user manual thoroughly prior to operating the massage chair. Store this booklet for future reference.



KAHUNA  CHAIR

## FUNCTION INTRODUCTION

1. With intelligent soft 3D massage machine in back, It can make the massage on neck, shoulder and waist parts more gentle, comfortable and suitable ; Adopting imitation of traditional Chinese medicine massage techniques, let you enjoy the massage feeling like a real professional massagist, in addition, it has the effect of unique shoulder pressing function.
2. With acupuncture point tracking detecting function. It can perform exact massage according to different people with different body height and shape.
3. With special heat function on the massage head and extra heat on back cushion it doesn't make sense heat massage for neck, shoulder and waist parts, help to relax the stressed muscle and promote blood circulation.
4. Combined with human body engineering research and development of super long SL-shaped curve guide, allows you to fully enjoy intimate massage from head to leg, achieving the result of rapidly alleviating the pressure of the spine.
5. One-button press to perform zero gravity lie down function. It can effectively alleviate the pressure on spine and joints, allowing you to experience the real zero gravity.
6. The forward sliding function of 4 inches from the wall. The backrest and seat frame move together, that can take full advantage of space, the design is full of humanization and will give you perfect feeling.
7. With blue-tooth technology, it can play the music of cellphone or tablet PC, help to keep a good mood and relieve the mental fatigue.
8. The foot parts with full scrapping function, with rollers in feet, combination with gentle air bag force to stimulate the soles.
9. Leg parts equipped with multiple airbags, perform pulse air pressure massage on legs, to promote blood circulation and restore the vitality.
10. Air pressure squeezing massage on your arms, which can promote blood circulation of blood capillary.
11. Equipped with multiple sets of airbags in waist and hip areas, which can completely cover the waist, hip and thigh parts, to effect air pressure squeezing massage alternately, and relieve the fatigue effectively.
12. The legrest and foot parts can be adjusted to any angle that you need, It can be extended and retracted within the range of 6 inches, suitable for different people to use.
13. The humanized simple remote control use the high definition big LCD, displaying the massage area, techniques and state in real time.

---

# CONTENTS

Thank you for choosing this SM 9000 3D SL-track massage chair.  
Please read this manual thoroughly before using the massage chair.  
Please keep this manual in a safe place for further reference.  
Please pay attention to SAFETY INSTRUCTIONS.

Safety Instructions	1
External structure parts	5
Internal structure parts	6
Mechanical components diagram	7
Mechanical components list	8
Installation	9
The adjustment before massage	13
Manual control	15
Operation instruction & function illustration	17
After massage	19
Clean and maintenance	20
Malfunction guide	21
Technical data	22



Please keep this manual in a safe place for future reference.

**Note** We reserve the right for design modification. It is subject to change without notice. The pictures in this manual are only for reference. Please refer to the actual product.





## SAFETY INSTRUCTIONS

- Please read this manual carefully to make sure the installation and operation of the massage chair is correct.
- “Safety Instructions” are provided in both Warning and Caution for important safety information.

Both Warning and Caution are important safety caution, please be more cautious.

 Warning	This sign indicates warning of causing possible death or hurt to body.
 Caution	This sign indicates caution of causing possible pain or damage to body.

### Use dry cloth to clean

	This sign indicates forbidden behavior.		This sign indicates self disassembly is forbidden.
	This sign indicates must follow instruction to operate.		This sign indicates correct operation of cable.

- The following should be kept for any further references.

## TECHNICAL DATA

### Technical data

Name	3D SL-track Massage chair	Power	200 W
Model	SM 9000	NW/GW	Main body :198.42 lb/ 246.92 lb Armrest : 59.52 lb/ 81.57lb
Input voltage	AC120V, 60Hz	Packing size	Main body 51.18x29.33x49.41 inch Armrest 61.61x16.54x27.95 inch
Safety design	Class 1		

## MALFUNCTION GUIDE



### FAQ and Troubleshooting

Trouble	Possible reasons	Troubleshooting
The massage chair doesn't work after power is on.	Check if the control is on or not.	Open control switch
	Not selected massage function	Choose massage function
	Check whether the plug and socket in poor contact.	Make sure plug and socket are connected.
	Wire or plug has visible damages.	Please contact service @kahunachair.com for checking and replacement.
	The fuse burned out.	Replace fuse of same specification.
	Something wrong with inner circuit.	Please ask appointed or authorized maintenance man for checking and repairing.
There is beep sound inside the massager while working.	It is sound of air pump, motor and mechanical parts.	Normal sound, no need to pay attention to it.
Different height of the left roller and right roller.	Massage rollers work on shifts.	Normal, no need to pay attention to it.
Sound suddenly becomes much louder while working.	Check if it is due to long time working.	Turn off the power to have the massager rest for over half an hour before next turn working.
	Inner parts fretted away due to long time work. It's normal	Please ask appointed or authorized maintenance man for checking and repairing.
Massage function suddenly stops while working.	Suddenly power-down	Connect the electricity power again
	Setting time is up.	Turn off the power to have the massager rest for over half an hour before next turn working.
Neither the backrest nor the legrest can be lay down.	Check if there are any obstacles; the chair overloads; for the sake of safety, sometimes the massage machine may automatically stop working.	Remove the obstacles; turn off the power to have the massager rest for over half an hour before next turn working.
The chair can't return to its original position.	Excessive operation; setting time is up.	Please ask manufacturer or appointed or authorized maintenance man for checking and replacement.
Electric wire or plug give out heat	It may work overload	Turn off the power to have the massager rest for over half an hour before next turn working.
	Other abnormal case	Stop using, and ask appointed maintenance man for help.

 Note: If the troubles are not caused by above reasons, please turn off the power switch and cut off the power, then contact the manufacturer or service agent to repair your chair.

## SAFETY INSTRUCTIONS



### Warning

	<ul style="list-style-type: none"> <li>Osteoporosis patient;</li> <li>People with heart disease including embedded pacemaker or other medical electronic device inside the body;</li> <li>For pregnant women or people with health issues, please consult doctor before use ;</li> <li>Patients with a high fever forbid to use this machine.</li> <li>Perceptual disabilities patients forbid to use this machine.</li> <li>People over 80 years old forbid to use this machine.</li> <li>Kids and the drunk people are not allowed to use the chair;</li> <li>Please don't sleep in the chair.</li> <li>Don't use the chair when your body is wet.</li> </ul>	People who are not suitable to use the chair
	<ul style="list-style-type: none"> <li>Make sure there are no kids or pets or other objects around (under, behind or in front of) the chair at the moment of backrest, leg-rest up/down or leg-rest retraction/extension from reclining position.</li> <li>During operation, if body is being abnormal, please stop the operation and go consult with your physician.</li> <li>Please do not take strong massage on the head.</li> <li>Do not massage belly or knees, be careful when massaging neck.</li> <li>Children or pets are not allowed to play on the chair especially during massage. Standing or sitting on the back or armrest is not allowed either.</li> <li>Those who move around with difficulty or can't express themselves must be taken care of strictly and continuously during massage.</li> </ul>	Accident/injury
	<ul style="list-style-type: none"> <li>Insert the plug of the chair into correct and suitable power socket.</li> <li>Make sure the plug is completely inserted into the socket to reduce short circuit or fire risk.</li> <li>Unplug the power when not in use, stop all massage functions and turn off on/off key before unplugging.</li> </ul>	Fire and electric shock
	<ul style="list-style-type: none"> <li>It is prohibited to use the massage chair while any items are covering the massage chair ventilation holes.</li> <li>Massage cushions of the chair are not allowed to fold for storage.</li> <li>The machine is forbidden for no-load running for a long time.</li> </ul>	Accident
	<ul style="list-style-type: none"> <li>Power cord, plug, socket can't be used in broken or loose contact condition.</li> <li>Don't use other electric power except rated voltage in case of fire, electric shock or any breakdown.</li> <li>Any broken, re-process, knotted, twisted power cord or pressed under heavy cargo is not allowed to use.</li> </ul>	Fire and electric shock
	<ul style="list-style-type: none"> <li>If the chair is dysfunctional, or is broken, splashed with water or falls into water, please have it repaired by professional repairman or send the chair to assigned service agent. Self-modification, disassembly or maintenance is forbidden.</li> <li>If power cord or plug is damaged, please don't replace it yourself, please contact us or appointed dealer for replacement.</li> <li>To avoid electric shock or body injury, please don't open or disassemble any part of the chair, there is not any attached part of the chair for maintenance by customers.</li> <li>Check leather or cloth material on the back and other areas is broken or not. If broken, even though it is small, please stop using the chair, unplug the power and have it repaired.</li> </ul>	Disassembly and maintenance



## SAFETY INSTRUCTIONS

### Caution

	<ul style="list-style-type: none"> <li>Please operate the chair when it is flat or on leveled place</li> </ul>	To avoid sudden falling.
	<ul style="list-style-type: none"> <li>Position the chair 4 inches from the wall to allow for sufficient space to recline up and down.</li> </ul>	To make sure the back lying.
	<ul style="list-style-type: none"> <li>The maximum suggested operating time is 20 mins. 5 mins for each position beginning with the slight- step massage. Along continuous massage in the same position may cause uncomfortable feeling.</li> </ul>	Too long time massage is bad for your body.
	<ul style="list-style-type: none"> <li>Before sitting on the chair to avoid injury please inspect everything to confirm that the massage heads are in the correct position.</li> </ul>	To avoid accidental injury.
	<ul style="list-style-type: none"> <li>Please make sure that the power switch is on "OFF" position before inserting the plug into the socket.</li> </ul>	To avoid the accident when turn on the power.
	<ul style="list-style-type: none"> <li>Turn off all controls before removing plug from outlet.</li> </ul>	To reduce short circuits and any fire hazard.
	<ul style="list-style-type: none"> <li>Make sure the plug is completely inserted into the socket.</li> </ul>	To avoid electric shock in any leakage or breakdown.
	<ul style="list-style-type: none"> <li>Checking whether there are any damages on the wire and make sure there are no water or rubbish on the wire.</li> <li>Installing the wire in a correct way. The plug must be inserted into socket with the connect, the connect couldn't be bent or cut off.</li> </ul>	To avoid electric shock in any leakage or breakdown.
	<ul style="list-style-type: none"> <li>Don't press with hands or step on the massage heads with feet.</li> <li>Don't put hands between the working massage heads.</li> <li>Don't put hands or feet in the gap of mechanical parts.</li> <li>Don't drop or insert anything into the slot of massage chair.</li> <li>Don't stand or sit or put anything on the backrest, armrest, or leg-rest.</li> <li>Don't stand on the chair during operation.</li> <li>Don't move the chair during operation.</li> <li>Don't pull out the plug or turn off the power during operation.</li> <li>Don't put your hands or head between leg-rest or beneath.</li> <li>Don't use the massage chair while wearing hair ornaments.</li> <li>Don't put hard things in pocket when take buttocks and huckle massage.</li> <li>Don't sit or press on the backrest when the chair is in reclining position.</li> <li>Don't use on bare skin or wearing thin clothes, thin clothes may cause better massage effect, But it also may cause irritation to the skin or cryogenic burns.</li> </ul>	To avoid accidents or injury
	<ul style="list-style-type: none"> <li>Keep the chair away from heat, wet, sharp things and corrosive, inflammable, explosive environment.</li> <li>To use electric blanket or other heating products on the chair is forssidden.</li> <li>Don't put in the space of dust serious or corrosive gas environment.</li> <li>Don't put the chair in a small space places or use in the bad air circulation places.</li> </ul>	To avoid fade, discolor on upholstery or hardened, deteriorated on PU.
	<ul style="list-style-type: none"> <li>Keep the chair away from stove or other heating products.</li> <li>Don't put the chair directly under the sun or other high temperature places.</li> </ul>	
	<ul style="list-style-type: none"> <li>Don't use the chair in outdoor.</li> </ul>	

## CLEAN AND MAINTENANCE

### Synthetic leather

#### General cleaning

Clean with tidy, soft and dry cloth slightly.



(Chemical or medical cleaning products are forbidden)



#### If leather is dirty

- Dip soft cloth into 3-5% neutral detergent solution, squeeze it then clean the stain on the surface gently.
- Wash cloth, squeeze it and wipe with detergent.

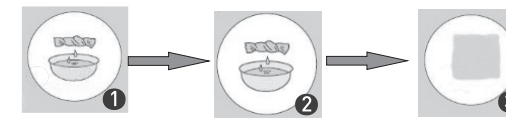

- Clean it softly with dry cloth.
- Allow to dry (air blower is prohibited)

### Cloth material

- Dip cloth into weak neutral detergent, squeeze it and clean the material surface. (Diluent, gas, alcohol are prohibited)



Brush the dirty parts with weak neutral detergent. (avoid excessive brushing)

- Excessive cleaning may cause damage to cloth material.

- Wipe with water-dipped but squeezed cloth.

- Allow to dry.



### Plastic parts

- Dip cloth into neutral detergent, squeeze it and clean.
- Wipe with water-dipped but squeezed cloth.
- Let it dry fully before using it.



### Clean the controller

- Wipe with soft cloth after squeezing.
- Allow to dry. Propellant, diluent or alcohol are prohibited.

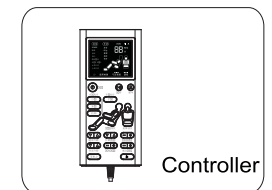

### About cleaning

- Before cleaning, unplug the electricity, don't touch plug with wet hands.
- Make sure hands are dry when plugging to the socket.
- If failed to follow the mentioned instruction, user may get electric shock or burned.



## AFTER MASSAGE

### Restoration of massage chair

- 1 Make sure there is no people or pet or anything within the range of backrest and legrest.



- 2 Make backrest and legrest restore to the normal position by controller.(or press ON/Off key to make backrest and legrest restore to the normal position)



- 3 Put the remote control back to the pocket after chair gets reset.



- 4 Put the pillow pad on to the right position.

- 5 Switch off the power.

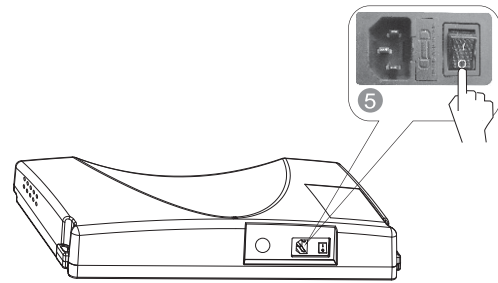

- 6 Unplug the electricity from the socket. (Attention: hold the right plug position)

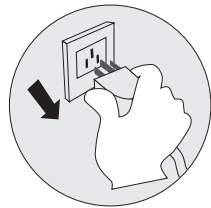

- 7 Clean the chair if necessary.

### ! Attention!

- After using, press ON/OFF to end all the massage method and wait for restoration.
- Make sure to cut the electricity to avoid any unexpected hurt to children or pets.
- After using, turn off the power, unplug the electricity. Avoid moisture, dirt and aging of insulation in case of causing damage.

## SAFETY INSTRUCTIONS

### ! Caution

	<ul style="list-style-type: none"> <li>• Don't use or store the chair in the wet environment like near the swimming pool, or bathroom.</li> <li>• Keep the chair and remote control dry at all time.</li> <li>• Don't use the chair when your body is wet.</li> </ul>	To avoid leakage or electric shock.
	<ul style="list-style-type: none"> <li>• Make sure to install the wire in correct way(Incorrect install way may cause electric shock. If you don't know how to install, please find a professional electrician)</li> <li>• Don't use plug adapter (If the enclosed plug doesn't match with socket, please don't change the plug by yourself and find a professional electrician to install a matched socket.)</li> </ul>	To avoid electric shock.
	<ul style="list-style-type: none"> <li>• Unplug the power before cleaning the chair.</li> <li>• Unplug the power after using the chair.</li> <li>• Unplug the power when any damage on the power.</li> </ul>	To avoid electric shock or fire hazard.
	<ul style="list-style-type: none"> <li>• Hold the plug to unplug the power but to not try to pull the wire to unplug the power.</li> <li>• Please turn off the power switch and unplug the power after massage.</li> </ul>	To avoid accidents
	<ul style="list-style-type: none"> <li>• Unplug the power immediately when electricity goes off.</li> </ul>	To avoid damage or accidents when power on again.

- ! Warning :**
- 1.Do not use it when gets wet.
  - 2.The disabled or people who need supervision.
  - 3.The chair has heat function, people who are insensitive to heat must pay high attention.

### Grounding instruction

The chair is equipped with a cord having a grounding conductor.The plug must be plugged into an appropriate socket that is properly installed and matched with the plug.

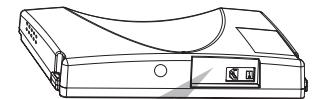

### Replace fuse

When the fuse is burned out, please turn off the switch and unplug the power. Open the electrical compartment lid which is located in the switch box. Using a same size fuse to replace the old one, then cover the lid. Or you can find an electrician to replace the fuse.

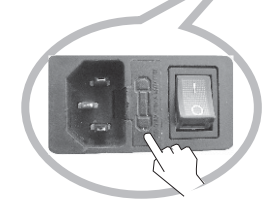

Earth wire is not allowed to be in these places

Gas pipe: probably cause explosion or fire.  
Phone wire and lightning rod: probably cause electric shock and fire when thundering.  
Water pipe: earth wire is useless where there are plastics

## EXTERNAL STRUCTURE PARTS

### External structure



## OPERATION | STRUCTION AND FUNCTION ILLUSTRATION

### Function illustration

#### Legrest Up

Press this button on controller, legrest goes up. Release the button, legrest stops moving, the angle is locked in this position.



#### Legrest Down

Press this button on controller, Legrest goes down. Release the button, Legrest stops moving, the angle is locked in this position.



#### Legrest up and backrest down

Press this button on controller, backrest goes down and Legrest go up. Release this button, backrest and Legrest stop moving, the angle is locked in this position.

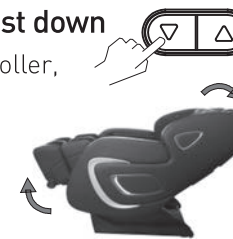

#### Backrest up and Legrest down

Press this button on controller, backrest goes up and Legrest go down. Release this button, back rest and Legrest stop moving, the angle is locked in this position.



#### Zero Gravity

Press the button "Zero Gravity", backrest go down and Legrest raise up, the chair go into Zero gravity status automatically. Press the Button again, the backrest and Legrest stop moving, and it will lock at this position. However to change the angels, we can keep comfortable massage status all the time.

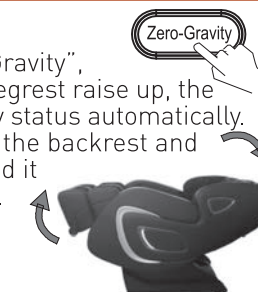

#### Legrest extend and retract

Legrest can extend or retract within a range of 6 inches.



#### Arm massage

Put arms between arm airbags before the embedded airbags before filled with air. It will preform pinch massage techniques to arms and hands after airbags inflating.



#### Shoulder massage

Multi-layer extrusion airbags is deployed on both sides of the shoulder. Achieve pressure shoulder stretch massage, relieve shoulder fatigue.



#### Foot roller massage

Footrest parts with roller massage and air pressure massage function. Through stimulating the foot reflex zones, and clear the body meridians, regulate and restore human organs function, improve the body resistance and immunity effectively.



- 1 Please make sure there are no people, no pets or any stuff within range for backrest to avoid unexpected hurt or property loss.
- 2 When adjusting the backrest, be careful the gap between the backrest and armrest.
- 3 When the Legrest is moving, please do not stand on or leave from the seat, and do not stop the legrest from moving in case of causing damage to the chair.
- 4 Please refer to control instruction for more details.



## OPERATION | STRUCTION AND FUNCTION ILLUSTRATION

### ON/OFF

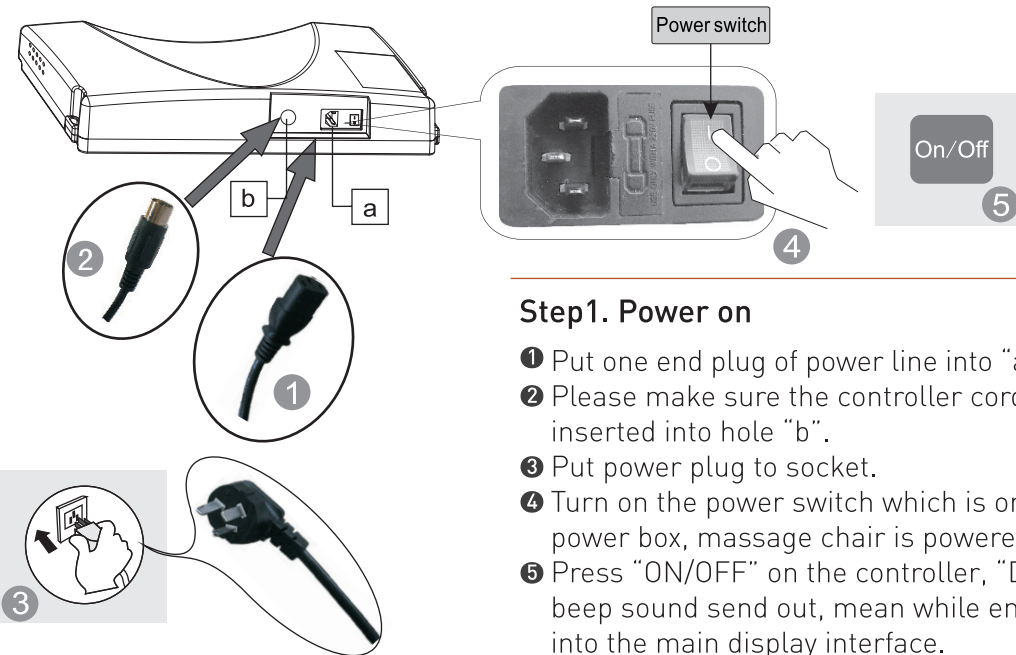

#### Step1. Power on

- Put one end plug of power line into "a" hole.
- Please make sure the controller cord to be inserted into hole "b".
- Put power plug to socket.
- Turn on the power switch which is on the power box, massage chair is powered.
- Press "ON/OFF" on the controller, "DI" beep sound send out, mean while enter into the main display interface.

#### Step2. Massage

- Operate according to controller operation instruction.
- When massage stops, massage machine will return to the default position, mean while "Shutting down" will be displayed on the controller, controller off after 2-3 seconds.

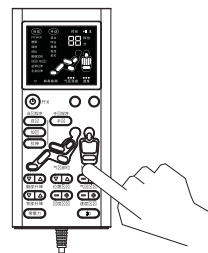

#### Step3. Turn off the power

- When the chair is On, press On/Off button to turn off the massage chair and it will restore automatically.
- Turn off the power switch on the bottom of the back of chair after the rollers stay at storage position.
- Unplug the power plug from the socket.



**Warning**

- Before using, pull up the pillow, back cushion etc. to check if the PU material is broken, if there is damage, please stop using, unplug the chair, and ask for repairment.
- Only plug to proper socket.



**Attention**

- Before sitting down, make sure there is no things pinched between armrest, legrest, backrest and seat of the chair.
- Make sure the chair is in returned position before using.
- Do not stand on it when using the massage chair.

## INTERNAL STRUCTURE PARTS

### Internal structure

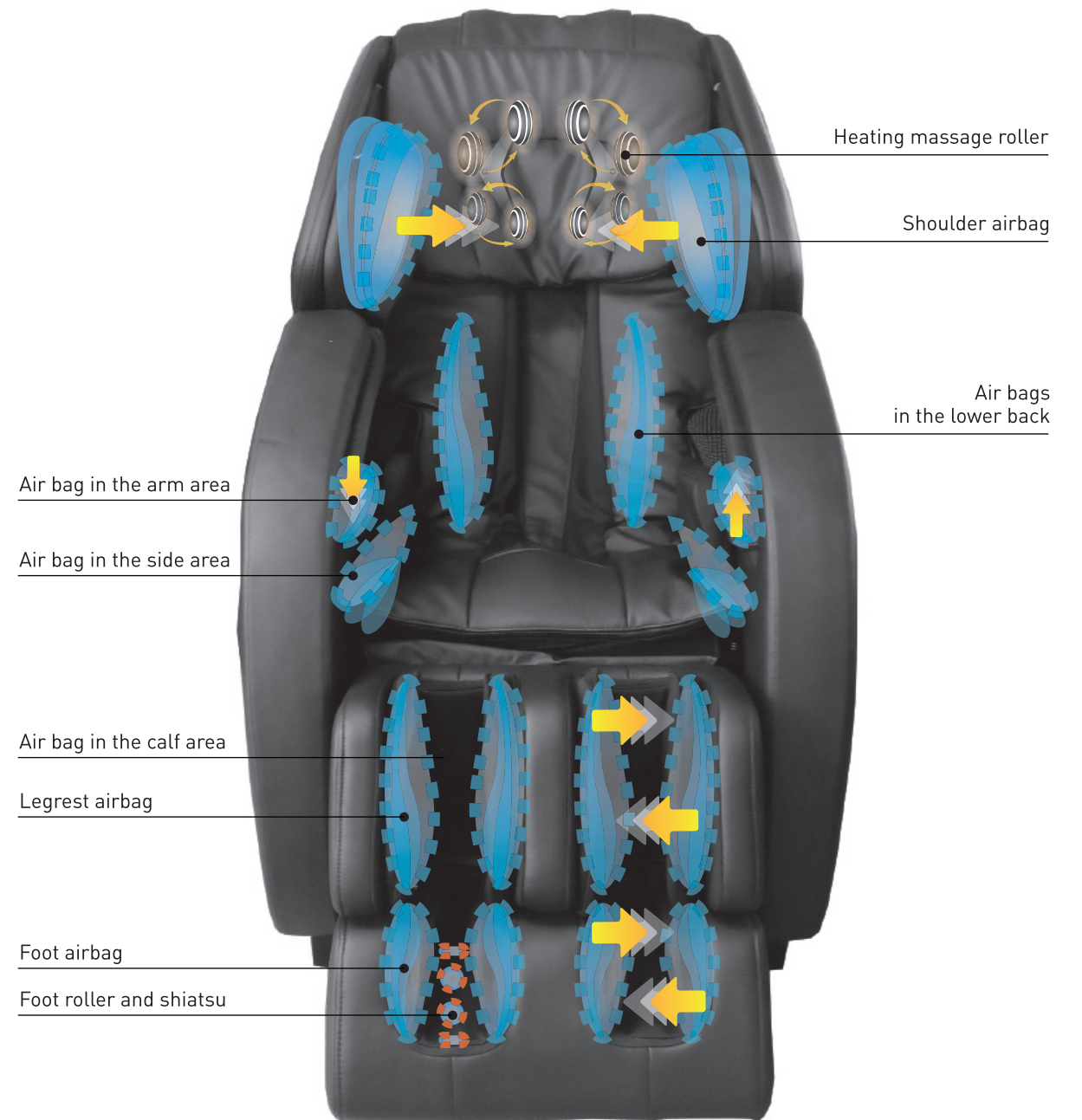





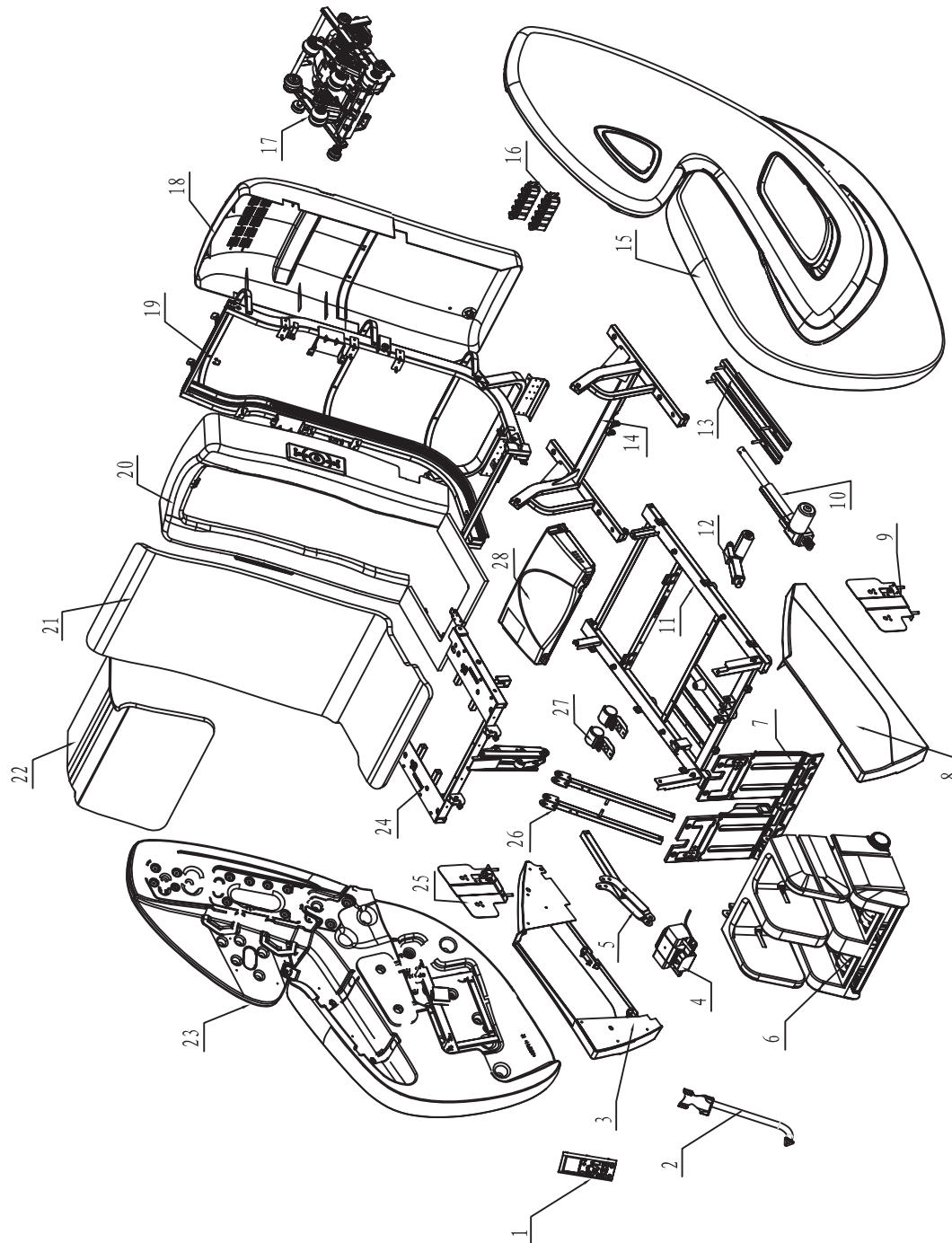









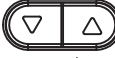
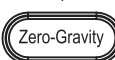

## MECHANICAL COMPONENTS DIAGRAM

### Explosion Diagram



## MANUAL CONTROL

	1. In standby position, press on/off to power on. In ON state, press on/off to power off and chair shall reset automatically and the seat part, leg-rest goes to the lowest and back-rest rises to the highest, remote control is off.
 Emergency off	2. In ON state, press this key to stop all the massage functions, all keys are defunct. If want to continue the massage, press on/off key to restart the control.
 Foot Roller	3. In ON state, press this key to start the foot rollers. Press it again to start the quick roller massage, press it for the third time to stop the foot roller.
 AUTO	4. In ON state, press this key to enter AUTO massage and select from the five auto massage programs on the screen in circles.
 Heat	5. In ON state, press this key to start the massage machine heat, with Heat 1 displaying on the screen.
 Stretch	6. In ON state, press this key to start stretch massage and choose from the two stretch programs on the screen in circles.
 Manual	7. In ON state, press this key to enter MANUAL massage, five massage techniques are displayed on the screen to choose in circles.
 Leg Up/Down	8. Press $\Delta$ key to raise the leg-rest, release that key, the leg-rest shall stop moving. Press $\nabla$ key to lower the leg-rest, release that key, the leg-rest shall stop moving.
 Back Up/Down	9. Press $\Delta$ key to raise the backrest and lower the leg-rest, release that key, backrest and leg-rest shall stop moving. Press $\nabla$ key to lower the backrest and raise the leg-rest, release that key, the back-rest and leg-rest will stop moving.
 Zero-Gravity	10. In ON mode, press this key, massage chair goes to Zero-Gravity position, now a body shape image is glittering on the screen. Press it again to reset the chair to original position.
 Back Roller	11. In ON state, after the body scan, press this key for a long time to adjust the massage machine position. In other cases, press this key to adjust the shoulder height position manually.
 Width	12. In ON state, after the shoulder height detection and during the manual massage, press this key to adjust the massage width.
 Air Intensity	13. In ON state, during the air massage, press this key to adjust the air massage intensity.
 Speed	14. In ON state, during the manual massage after the shoulder height detection, press this key to adjust the massage speed.
 3D	15. In ON state, after body scan during the manual massage, press this key to adjust the 3D intensity.
	16. In ON state, press any part to start that part's air massage. For every part, press it repeatedly to turn on or turn off that part's air massage.
	17. In ON state, during the manual massage, select the massage position by this key, it allows for multiple choice. As for the corresponding information, please refer to the screen display.

## MANUAL CONTROL

### Manual control

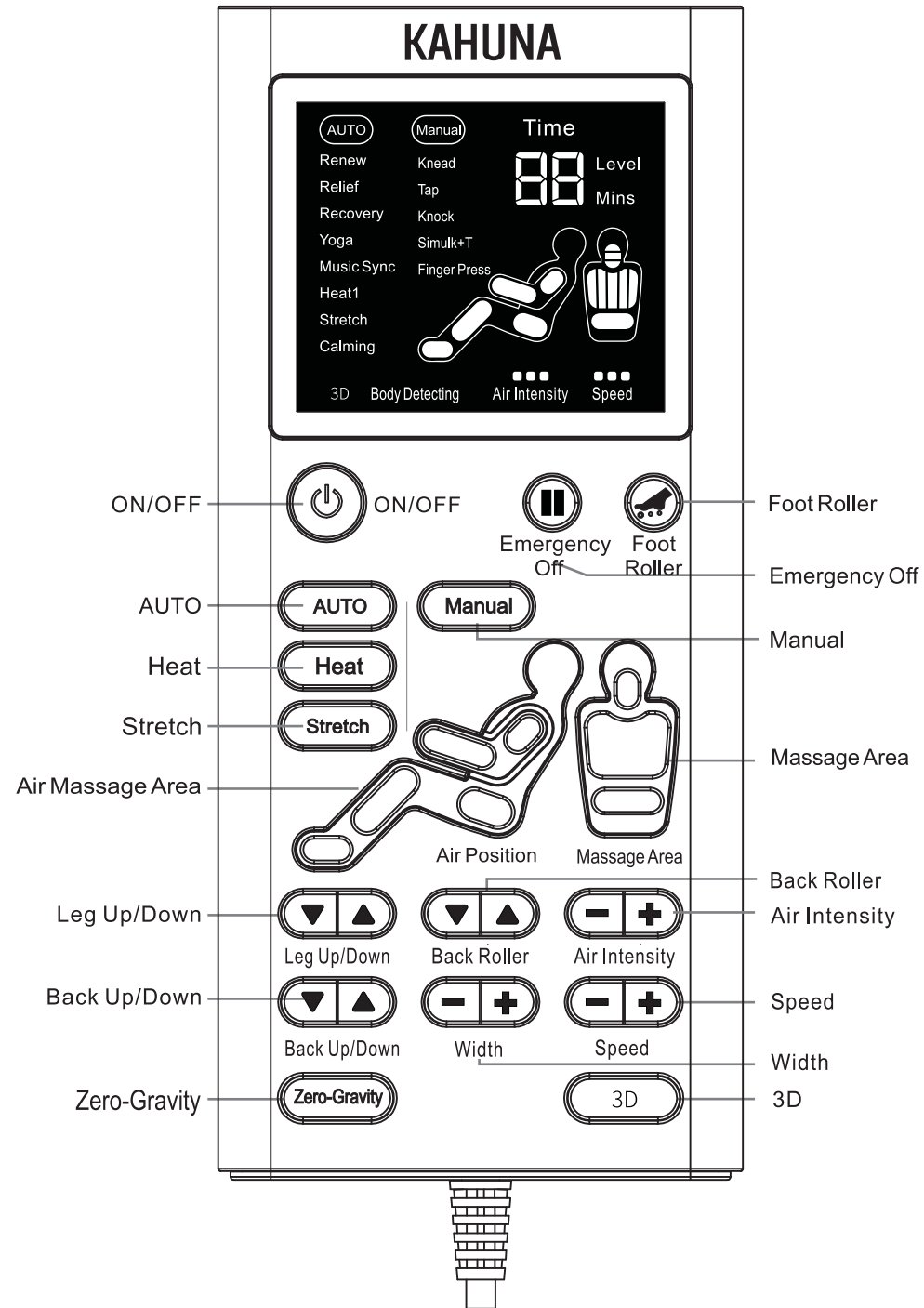

## MECHANICAL COMPONENTS LIST

### Mechanical components list

No.	Name	Q'ty	No.	Name	Q'ty
1	Remote control	1	22	Pillow	1
2	Controller bracket	1	23	Right shoulder and armrest assy	1
3	Right side fender	1	24	Seat frame surface assembly	1
4	Air pump assembly	2	25	Right side of seat airbag assembly	1
5	Connecting rod	1	26	Seat support bar	2
6	Legrest & footrest	1	27	Castor	2
7	Front fender	1	28	Power case assembly	1
8	Left side fender	1			
9	Left side of seat airbag assembly	1			
10	Backrest electric actuator	1			
11	Bottom seat frame assembly	1			
12	Footrest electric actuator	1			
13	Sliding rail	2			
14	Top seat frame assembly	1			
15	Left shoulder and amrest assy	1			
16	Electric magnetic valve	2			
17	Massage machine	1			
18	Back cover assembly	1			
19	Back frame assembly	1			
20	Backrest plastic front cover and seat plate assembly	1			
21	Back and seat cushion	1			



## INSTALLATION

### Installation

#### Step1. How to move the chair

- Take out the back seat cushion box from the main box first, and then grasp left and right metal frame, take the chair body from the main carton box.
- Take out the pillow, back seat cushion, power cord, controller bracket, remote control, left and right side airbags of seat from back seat cushion box. (As shown th the pictures)



- Take out the left, right shoulder and armrest from the armrest carton box. Catching the two side of the shoulder and armrest and take them out slowly. Put the shoulder and armrest on the table or ground in flat (pay attention to prevent scratches). Catch the shoulder and armrest two sides from the front of it and take it slowly when install the shoulder and armrest.



- Taking out the legrest device from the legrest carton box, catching the front and back two sides of the legrest and take them out.



## THE ADJUSTMENT BEFORE MASSAGE

### How to move massage chair



Don't move chair when it's working in case of accidents or damage

#### How to move

- Bind the cables and put them in the seat to avoid damage when moving.
- If you plump the chair, it may damage the inner parts of the chair.
- Don't use the castor if the floor is wooden or other easy damaged material. It will need 2 or more people to lift the chair.
- Make sure the power is off and the plug doesn't touch the floor (It's better to let the chair in standing status to avoid the back crashing the floor)

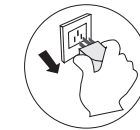

#### Normally

Lift up the legrest to make the gravity fall on the castor. Then push chair to destination and set it down.

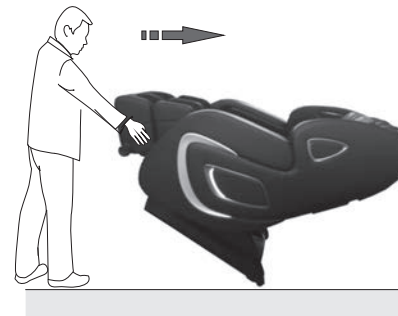

Please hold the footrest to move the chair as shown in the picture in case any scratches on the leatherette

### Adjustment before massage

#### Before adjustment

- Please make sure the massage head in the seat part before sitting on the chair.

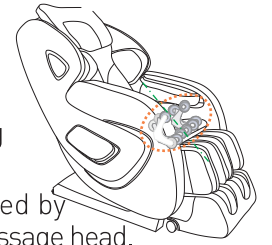

- To avoid injures caused by wrong position of the massage head.

#### Acupuncture point tracking detecting confirm

When acupuncture point position is being detected, if massage head can't detect the effective shoulder height position, The actual shoulder height position was default to the middle part of back.

#### Right position

Your back ding to the chair back, the head clings to the pillow.



The remote control gives "beep" sound after acupuncture point tracking detecting finished, when micro-adjustment is needed, just press up/down key on the remote control.  
- Avoid for the massage head detecting your acupuncture point position not right, otherwise you won't get good massage.

#### Kind suggestion



- When you feel the intensity isn't strong enough, take off the pillow or cushion.

- Because the chair is heavy, it may ruin your floor in long time setting. Please put a blanket or other soft things to protect your floor.







## THE ADJUSTMENT BEFORE MASSAGE

### Environment

#### ⚠ Caution

-  Don't use the chair in wet places like near the swimming pool and bath room to avoid leakage or electric shock.
-  Don't use under the sunlight or near stove or other heating place to avoid upholstery being deteriorated.
-  Please use chair in a flat place to avoid chair falling or noise or other unexpected troubles.

#### • Check places in front

Check the areas when back and leg are extending, make sure no people, pets or other things are around.



#### • Check power cable, plug

- (1) Clean the dust on plug on time. (using dry cloth).
- (2) No damage, re-do, bend, stretch, tie or press with heavy thing (especially can't be pressed by the chair) on power cable.



### Check environment

#### Space size for using the chair

- At least 4 Inches from wall.



- At least 11.8 Inches in front of the leg.

#### Check surroundings

When the backrest or legrest reclines or extends, please pay attention to:  
 (1) Check any person or things in every direction.  
 (2) Check the space size.

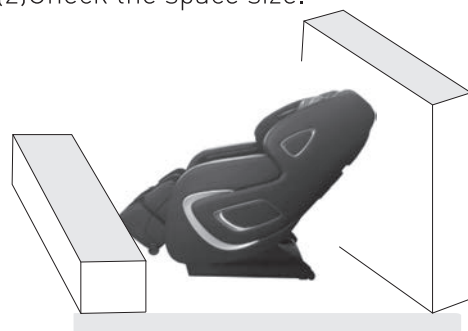

## INSTALLATION

### Installation

#### Step 2. Massage chair position return

After take out the main chair body, ① Take out the power cord, insert one end of power cord to the socket on power box, another end insert into power socket. ② Turn on the power switch on power box, massage chair in power on status, backrest goes up and seat goes down. ③ After backrest return, turn off the switch, unplug the power plug. (Refer to step 7, after the assembly)



#### Step 3. How to assemble the legrest

Install the legrest to the main body, ① Unscrew the bolt from hanger of legrest. ② connect 3 air pipes on legrest with air tap on main body, from left to right is grey, brown and black pipe. ③ Connect power line with power socket tight. ④ raise the rotation shaft board on hangers, raise the legrest with hands, put rotation shaft into hangers on main body, and put rotation shaft board down. ⑤ screw it back tight.

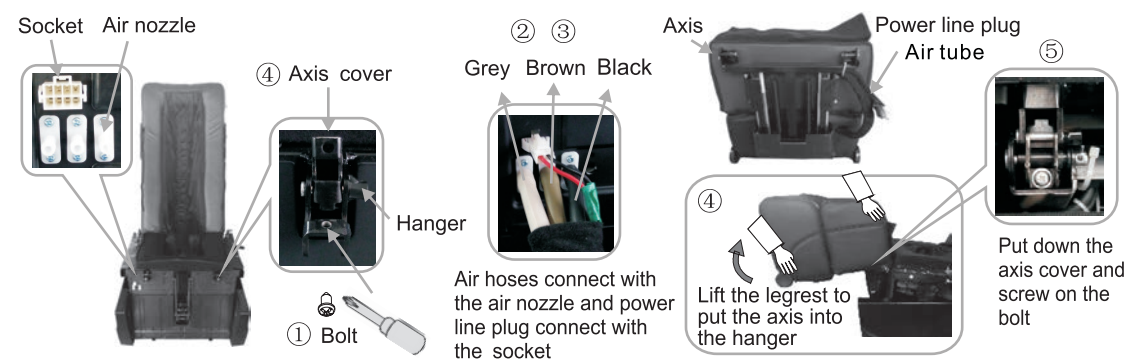

# INSTALLATION

## Installation

### Step 4. Assemble left and right shoulder and armrest

① Unscrew the M6 bolts on the seat frame with cross screwdriver. ② Lift shoulder and armrest, put shoulder massage device inside near to backrest side, and put fixed axle 1 into fixed hole 1 on backrest side, and make shoulder in right position. ③ Connect the wire from shoulder part to the socket on the side backrest. ④ Make fixed hole 2 on top of shoulder part align to fixed axle 2 which on top of backrest. ⑤ Make two fixed hole 3 on shoulder align to the two fixed axle 3 on the side of backrest. ⑥ Put the mentioned fixed axle to fixed hole and insert to right position, move downward the shoulder, and armrest put the square tube on armrest into plate on seat frame side, it is completely fixed until you can not move downward any more. ⑦ Make the front and back panel on armrest match bolt hole on the seat metal frame, screw on the M6 screws tightly. ⑧ Connect the air hose from armrest to the air hose from seat. ⑨ Connect the LED wire from armrest to the LED wire from seat. Note: Please make sure not to squeeze the air hose, LED wire during installation.

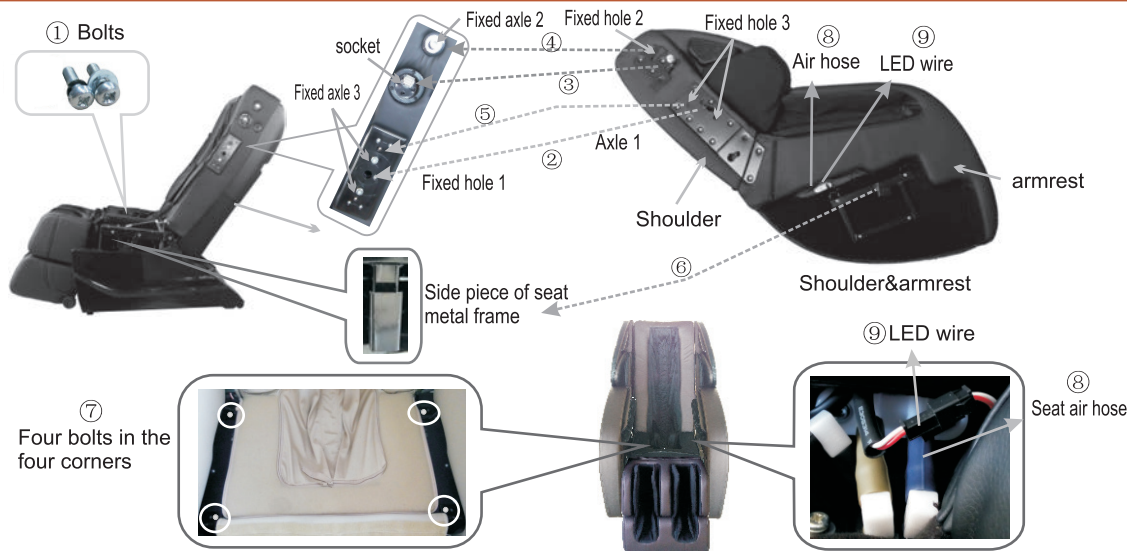

### Step 5. Installation of left and right side airbags of seat and remote controller

Assemble left and right side airbags of seat: ① Take out the left and right side airbags of seat, make the side with zipper face to the seat, make the two cylindrical pins align to the two hole on the seat frame, then press down straightly, make sure the connect tightly. ② Connect the air hose from air bag to the air hose connector on the back side of seat, around the zipper of air bag, make sure the connect tightly. Assemble controller and bracket: Screw out 3pcs M5\*15 screws on the outward of right armrest, put controller bracket to the hole, and fix with 3 screws, cover screws by the cover on support bracket, then put controller to controller holder.



# INSTALLATION

## Installation

### Step 6. Connect the zipper or velcro

Put the back seat cushion, head pad onto the backrest and connect the two parts with zipper and velcro.



### Warm tips

In order to get exact correct body test data for comfortable massage effect, when you sit on the chair, please make the bottom rim of the head pad flush with your ears before zippering the said two parts.

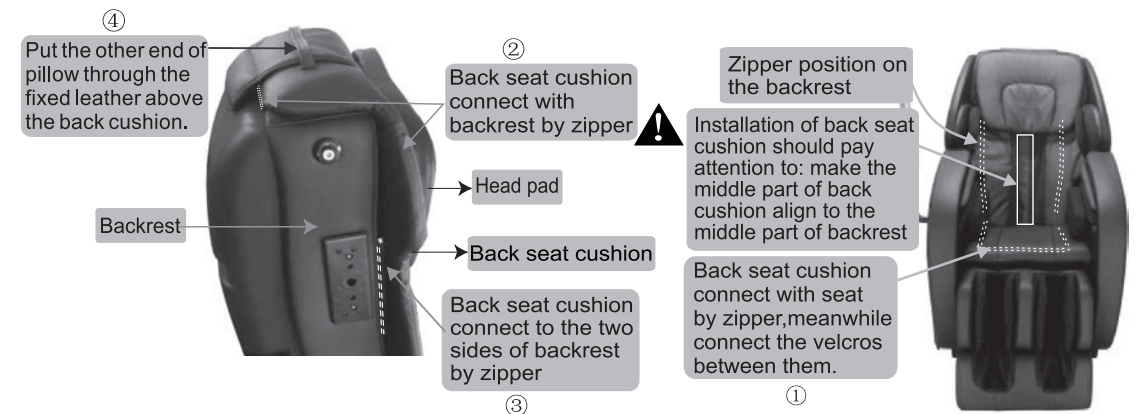

### Step 7. After the Assembly

After the assembly, please operate the chair in this order:

- ① Plug the cable line in the hole a on the power box as shown in the right picture.
  - Hole A connect with one end of cable line.
  - Hole b insert plug of the remote control.
- ② Insert the plug of cable line into the socket.
- ③ Switch on.
 

[ Power Switch 0/1, press 1 to power on, press 0 to power off.]
- ④ Enjoy the massage by using the remote control.

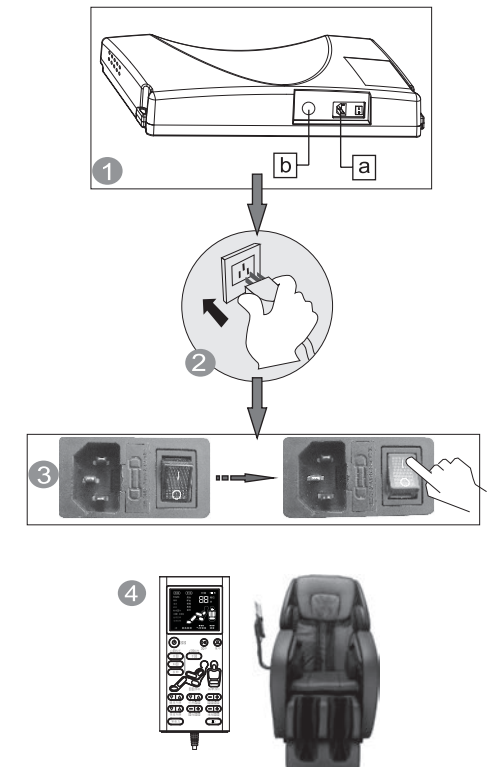

Make sure the switch is off before you insert the plug of cable line into the socket.